

TIPO TYPE		POTENZA NOMINALE NOMINAL POWER		POTENZA ASSORBITA INPUT POWER	AMPERE		Q = PORTATA - CAPACITY											
Monofase Single-phase	Trifase Three-phase	P2		P1	Monofase Single-phase	Trifase Three-phase	Prevalenza manometrica totale in m.C.A. - Total head in meters w.c.											
		HP	kW	kW			m³/h	0	1,5	3	4,5	5,4	6	7,5	9	10,5	12	
CNB 150/A	CNB-T 150/A	1,5	1,1	2	8,8	4	46	45	44	42	40	38	31					
CNB 150/B	CNB-T 150/B	1,5	1,1	2	8,8	4	40	39,5	39	38	37	36	32	27	20			
CNB 200	CNB-T 200	2	1,5	2,3	10,5	4,7	44	43,8	43,5	42,5	41,5	40,5	37	32	25			
CNB 300	CNB-T 300	3	2,2	3	13,5	5,2	49	48	47	46,5	46,3	46	43	38,5	32	25		

## APPLICAZIONI

Elettropompe centrifughe bigiranti indicate per aspirazioni fino a 7mt. Adatte per usi civili e industriali, per il sollevamento di acqua pulita e liquidi chimicamente non aggressivi. Particolarmente adatte per impianti di pressurizzazione.

## LIMITI D'IMPIEGO

- Temperatura liquido fino a 35°C (per un uso domestico secondo EN 60335-2-41)
- Temperatura max. liquido: 35°C (per altri impieghi)
- Temperatura ambiente fino a 40°C
- Altezza d'aspirazione manometrica fino a 7 mt.
- Servizio continuo

## MOTORE

- Monofase 230V-50Hz
- Trifase 230/400V-50Hz
- Motore elettrico ad induzione a 2 poli (n = 2850 min<sup>-1</sup>)
- Isolamento Classe F
- Protezione IP 55

## MATERIALI

- |                     |                      |
|---------------------|----------------------|
| - Corpo pompa       | Ghisa                |
| - Supporto motore   | Ghisa                |
| - Girante           | Noryl                |
| - Diffusore         | Noryl                |
| - Albero motore     | Acciaio Inox         |
| - Tenute meccaniche | Ceramica/Grafite/NBR |

## APPLICATION

Twin impeller centrifugal water pumps for suction up to 7 mt. Suitable for civil and industrial purposes and to drain clean water and non-aggressive liquid. Particularly suitable for high pressure systems.

## OPERATING CONDITIONS

- Liquid temperature up to 35°C (for home use according to EN 60335-2-41)
- Max. liquid temperature: 35°C (for other uses)
- Ambient temperature up to 40°C
- Total suction lift up to 7 mt.
- Continuous duty

## MOTOR

- Single-phase 230V-50Hz
- Three-phase 230/400V-50Hz
- Two-Pole induction motor (n = 2850 min<sup>-1</sup>)
- Insulation Class F
- Protection IP 55

## MATERIALS

- |                    |                      |
|--------------------|----------------------|
| - Pump body        | Cast Iron            |
| - Motor Support    | Cast Iron            |
| - Impeller         | Noryl                |
| - Diffuser         | Noryl                |
| - Shaft with rotor | Stainless Steel      |
| - Mechanical seal  | Ceramic/Graphite/NBR |

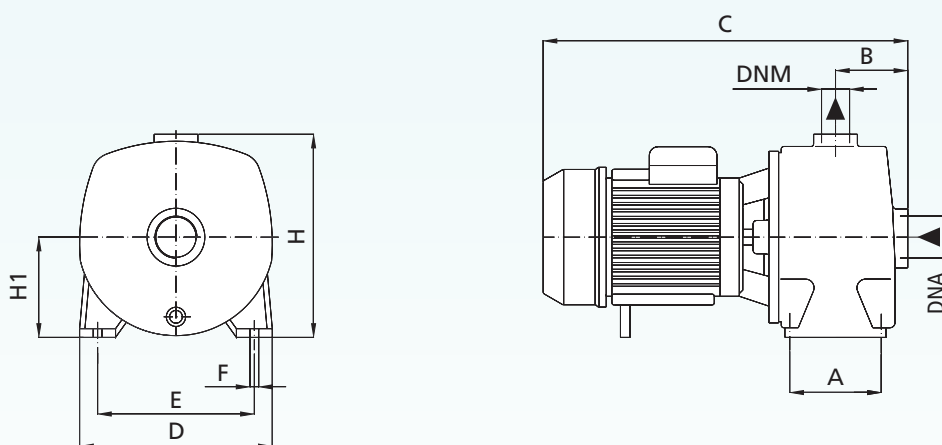

TIPO TYPE		DIMENSIONI mm - DIMENSIONS mm										DIMENSIONI DIMENSIONS mm			PESO WEIGHT	
Monofase Single-phase	Trifase Three-phase	A	B	C	D	E	F	H	H1	GIRANTI IMPELLERS	DNA	DNM	P	L	H	Kg
CNB 150/A	CNB-T 150/A	108	76,5	390	200	160	10	237	114	2	1" 1/2	1" 1/4	235	490	295	21,9
CNB 150/B	CNB-T 150/B	108	76,5	390	200	160	10	237	114	2	1" 1/2	1" 1/4	235	490	295	21,9
CNB 200	CNB-T 200	108	76,5	390	200	160	10	237	114	2	1" 1/2	1" 1/4	235	490	295	24,5
CNB 300	CNB-T 300	108	76,5	444	200	160	10	237	114	2	1" 1/2	1" 1/4	235	490	295	25,3